

Contact resistance: $\leq 20\text{m}\Omega$
 Insulation resistance: $\geq 1000\text{m}\Omega$
 Plugging force: $\geq 0.05\text{kg/p}$, $\leq 0.1\text{kg/p}$
 Rated current: 1A / pin
 Ambient temperature: $-55^{\circ}\text{C} \sim 105^{\circ}\text{C}$
 Welding temperature and time: $\leq 235^{\circ}\text{C}$, $\leq 3\text{S}$
 Contact material: phosphor bronze, nickel plating $\geq 130\mu$
 Insulating base: PBT
 Withstand voltage: 1000VAC 60s
 Salt spray test: no rust for 24 hours
 Settling salt spray concentration: $(5 \pm 1)\%$ NaCl (M / M)
 Test chamber temperature: $(35 \pm 2)^{\circ}\text{C}$

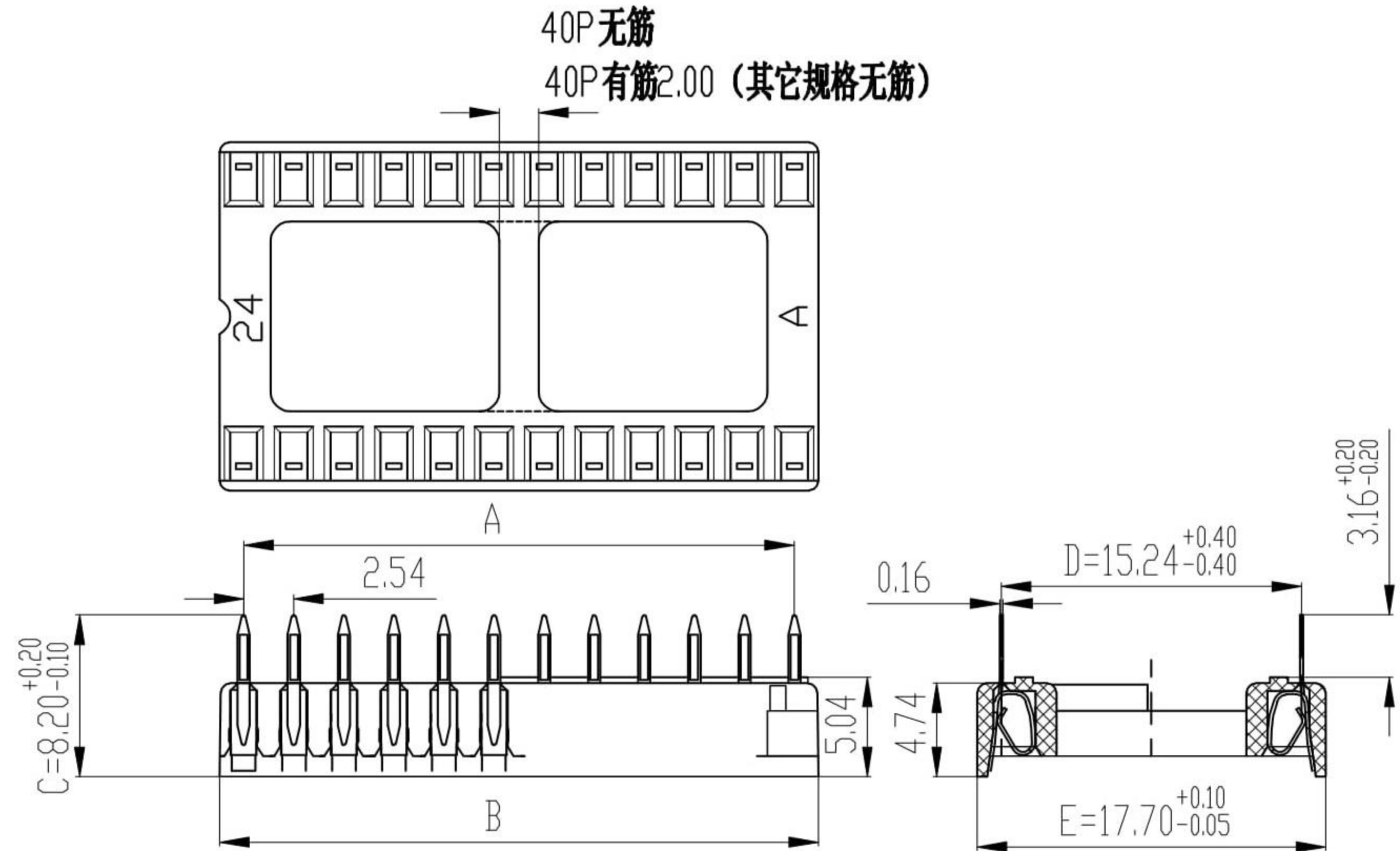

规格	A	B	C	D	E
24	27.94 ^{+0.10} / _{-0.10}	30.48 ^{+0.10} / _{-0.10}	8.20 ^{+0.20} / _{-0.10}	15.24 ^{+0.40} / _{-0.40}	17.70 ^{+0.10} / _{-0.05}
28	33.02 ^{+0.10} / _{-0.10}	35.56 ^{+0.10} / _{-0.10}			
32	38.10 ^{+0.10} / _{-0.10}	40.64 ^{+0.10} / _{-0.10}			
40	48.26 ^{+0.10} / _{-0.10}	50.80 ^{+0.10} / _{-0.10}			
40/筋	48.26 ^{+0.10} / _{-0.10}	50.80 ^{+0.10} / _{-0.10}			
42	50.80 ^{+0.10} / _{-0.10}	53.34 ^{+0.10} / _{-0.10}			
48	58.42 ^{+0.10} / _{-0.10}	60.96 ^{+0.10} / _{-0.10}			

符号	修改前记录	修订者	日期	XX. ^o ±3°	X.±0.2	核准 APPD	CONNECTAR							
				X. ^o ±1°	X.X±0.15	审核 CHECK								
				X.X ^o ±0.5°	X.XX±0.10	设计 DESIGN	产品名称 PART NAME	SNIC109-2.54W	图纸编号 DOC NO	材质 MATERIAL	PBT	数量 QUANTITY		比例 SCALE
				X.XX ±0.1 °	X.XXX±0.05	绘图 DRAWN	模具编号 PART NO		投影法 PROJECTION	版本 REV	A	单位 UNITS	MM	张号 SHEET