

Dec.1.2020 Copyright 2020 HIROSE ELECTRIC CO., LTD. All Rights Reserved.  
In case of consideration for using Automotive equipment / device which demand high reliability, kindly contact our sales window correspondents.

△ (Part No. 4 shape change)

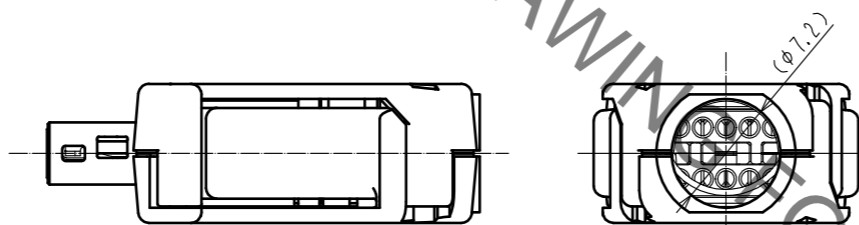
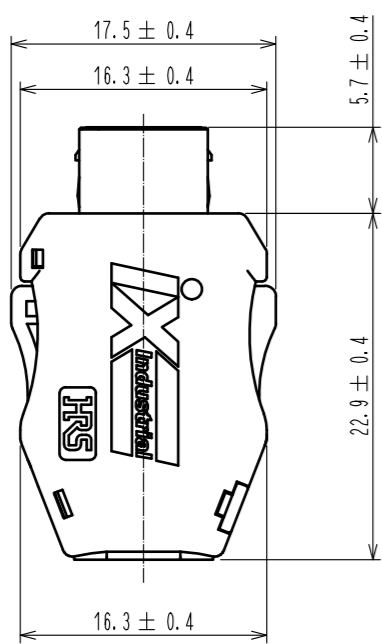
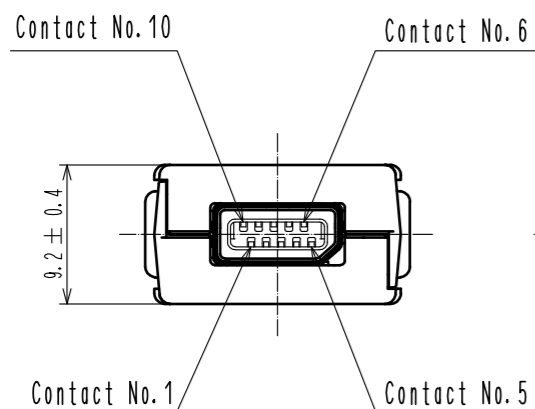
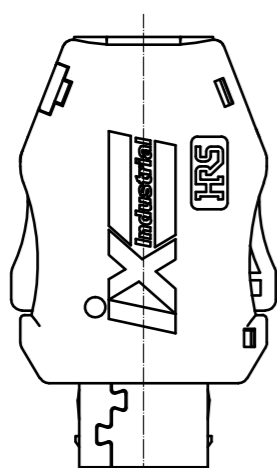

Notes. 1. Applicable cable condition is shown below.  
In case of using a not applicable cable, please contact our sales representative.  
Refer to the technical specification (ETAD-E3164-00) for wiring and assembly procedure.

Applicable Cable	
Items	Applicable Condition
Conductor size	AWG # 28-22
Insulation O. D.	φ 1.55 mm MAX.
Braid Shield	Tin plating
Sheath O. D.	φ 6.3 -7.2 mm

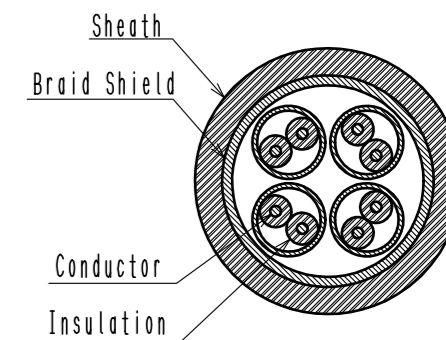

2. This product (Type B) is used for non Ethernet applications like signaling, serial or other industrial bus communication systems.  
Please use Type A for 10/100Mbit/s and 1/10 Gbit/s Ethernet communication.

Mating Shape

Type A

Type B

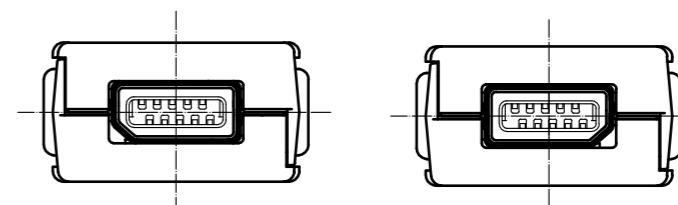

3. This product except plug unit is packed separately by the types of parts.  
Shield Shell is packed in pre-bended state. (See next page.)

3	Stainless Steel		7	PC	Dark gray, UL94V-0		
2	PA	Black, UL94V-0	6	Stainless Steel	Nickel 0.2 μm min		
1	Copper Alloy	Contact area : Gold 0.2 μm min	5	Stainless Steel	Nickel 1 μm min		
		Wiring area : Gold 0.03 μm min	4	PA	Black, UL94V-0		
NO.	MATERIAL	FINISH . REMARKS	NO.	MATERIAL	FINISH . REMARKS		
UNITS mm		SCALE 2 : 1	COUNT 1	DESCRIPTION OF REVISIONS DIS-E-00003265	DESIGNED KI. KAGOTANI	CHECKED MN. KENJO	DATE 20200925
<b>HRS</b> HIROSE ELECTRIC CO., LTD.		APPROVED : RI. TAKAYASU 20170328	DRAWING NO. EDC-129507-00-00				
		CHECKED : KI. NAGANUMA 20170327	PART NO. IX40G-B-10S-CV(7.0)				
		DESIGNED : TS. SAKAIZAWA 20170327	CODE NO. CL251-0032-0-00				
		DRAWN : TS. SAKAIZAWA 20170327			△ 1/2		

Dec.1.2020 Copyright 2020 HIROSE ELECTRIC CO., LTD. All Rights Reserved.  
 In case of consideration for using Automotive equipment / device which demand high reliability, kindly contact our sales window correspondents.

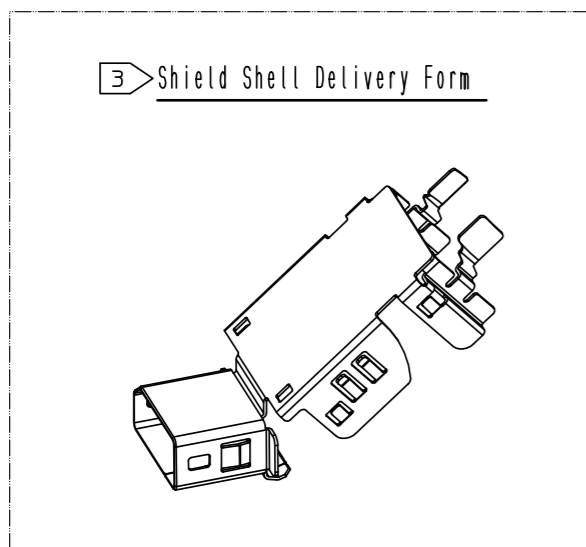

Product Structure

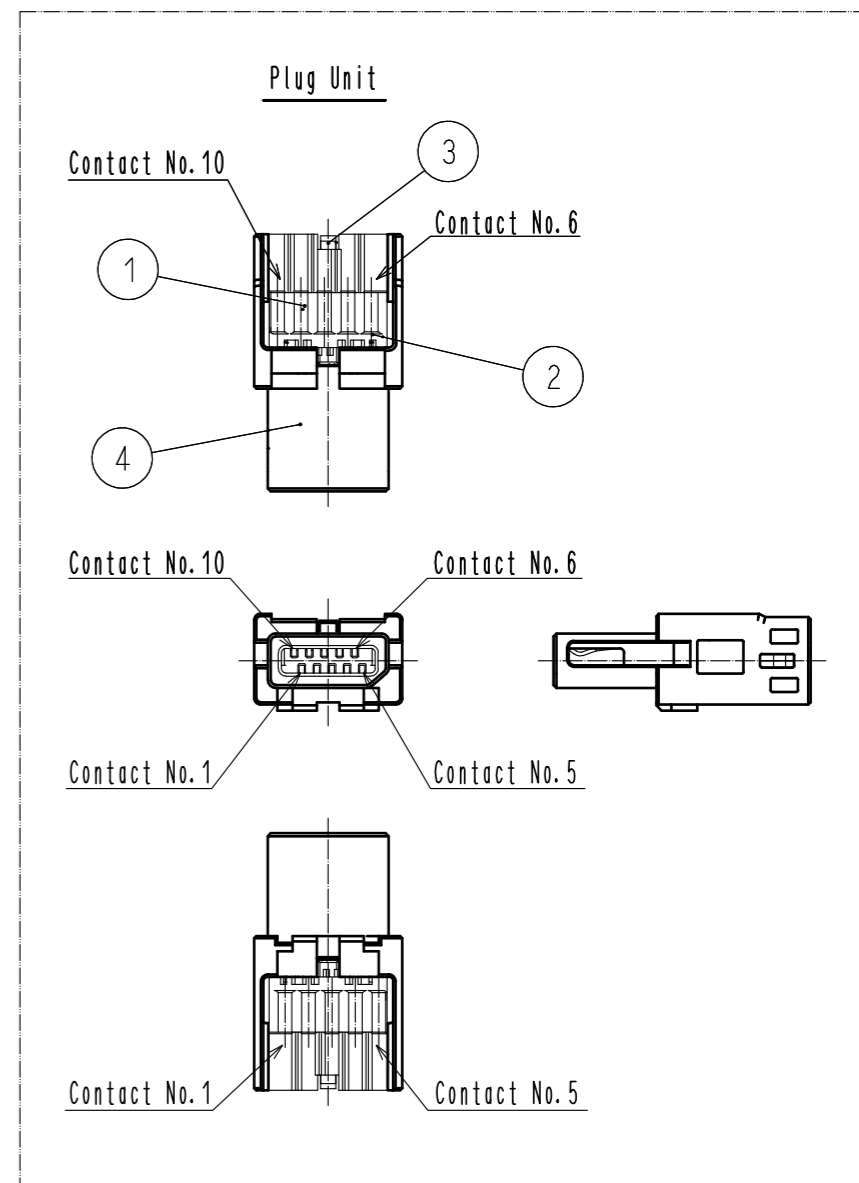
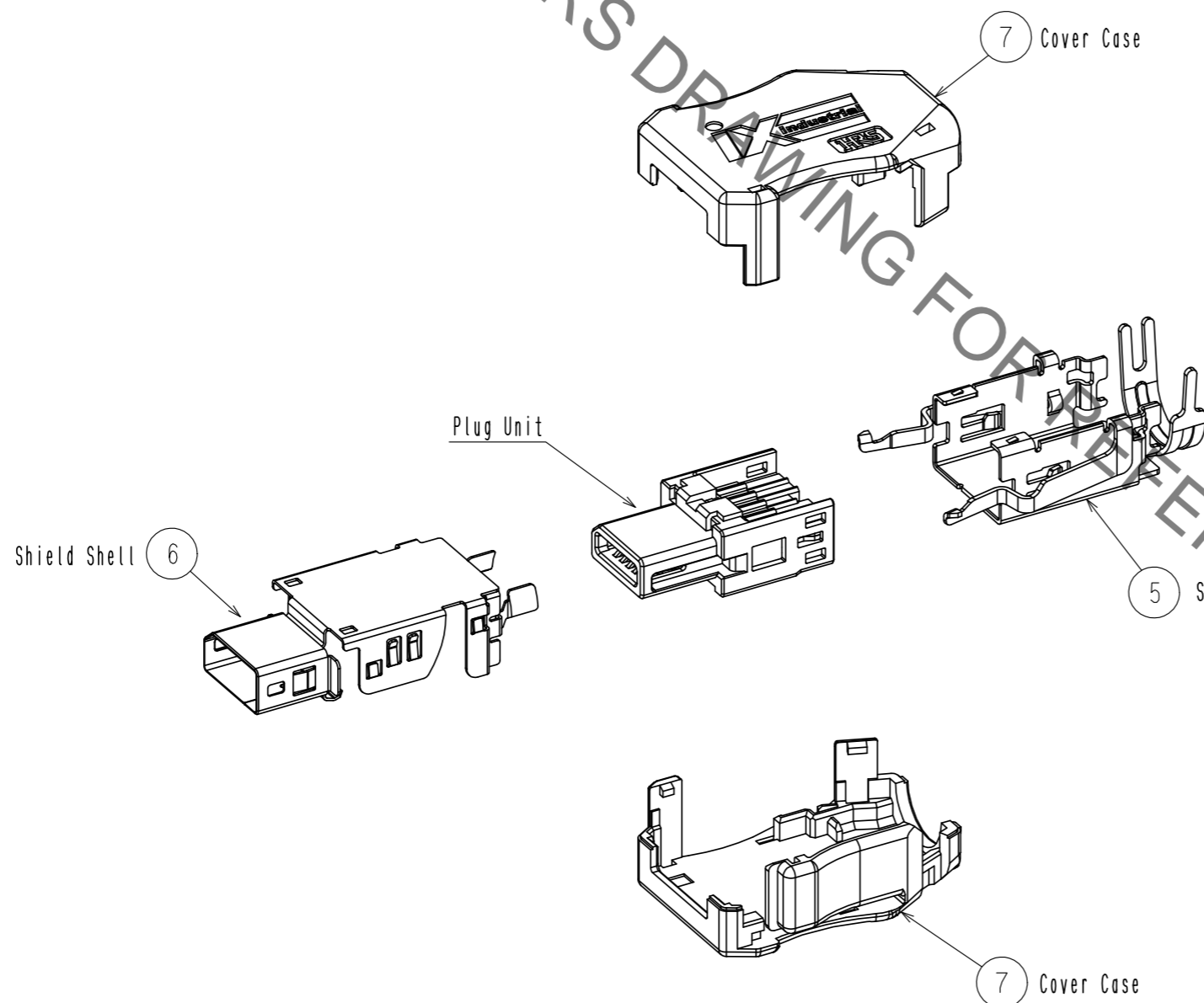

Mating Condition

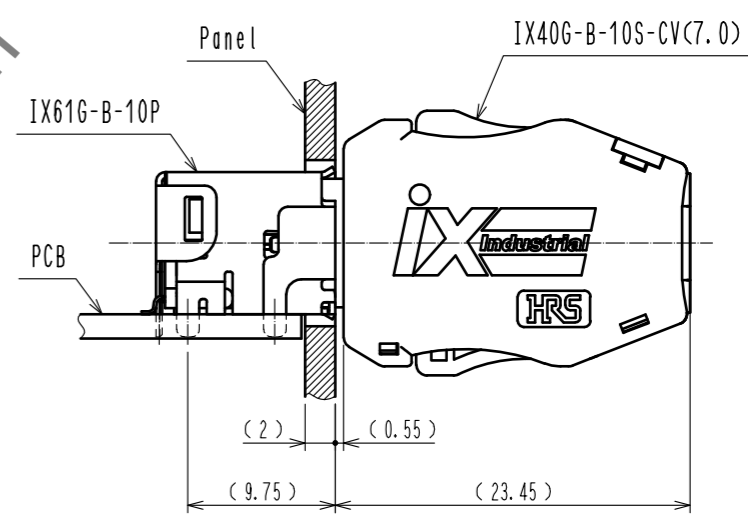

<b>HRS</b>	DRAWING NO.	EDC-129507-00-00
	PART NO.	IX40G-B-10S-CV(7.0)
	CODE NO.	CL251-0032-0-00
		4/2