

THIS DOCUMENT IS THE PROPERTY OF
KEYSTONE ELECTRONICS CORP. AND
SHALL NOT BE REPRODUCED, DISTRIBUTED
OR USED AS A BASIS FOR MANUFACTURE
WITHOUT PRIOR WRITTEN PERMISSION
FROM KEYSTONE ELECTRONICS CORP.

ACTUAL SIZE

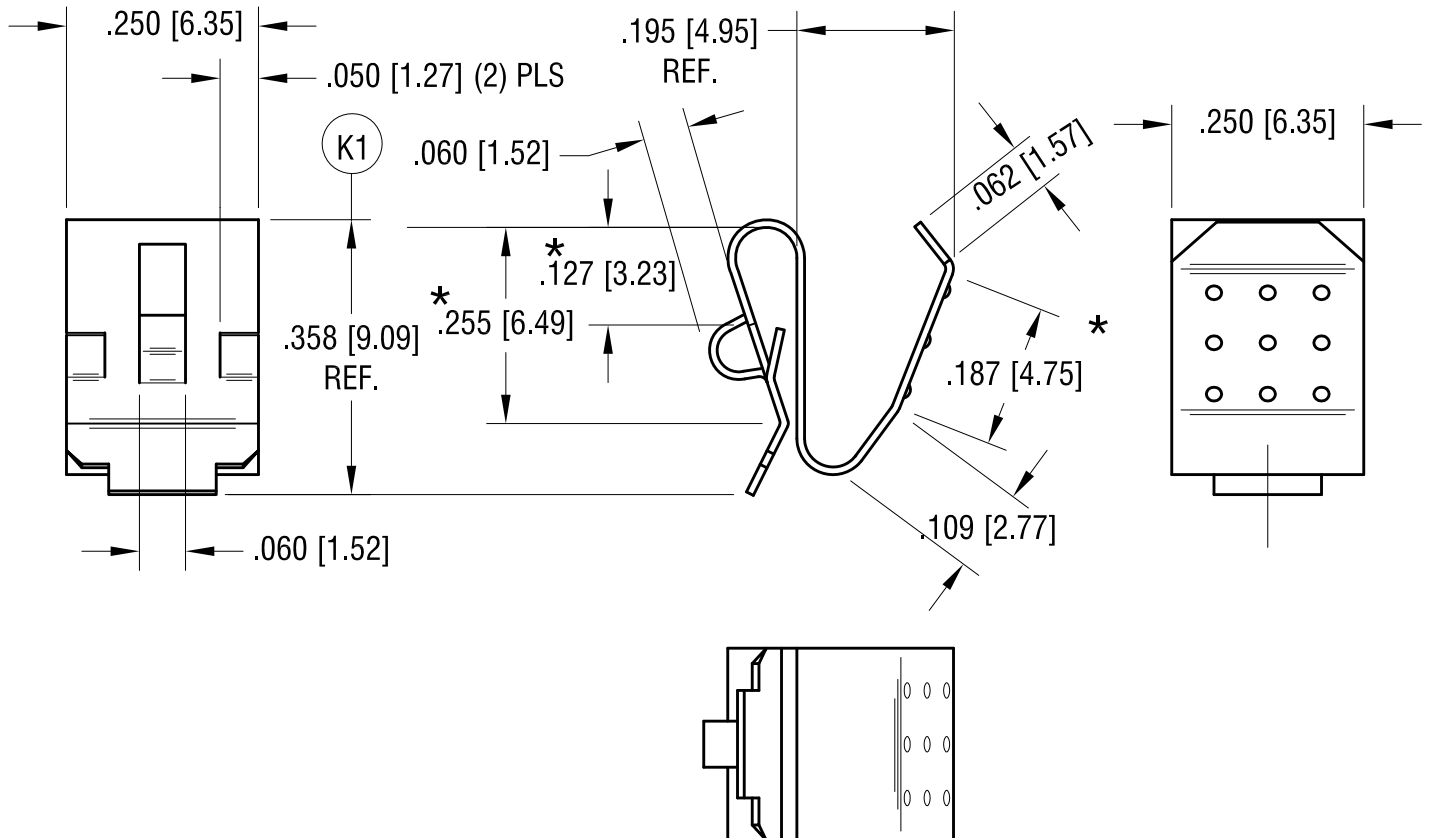
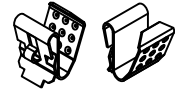

NOTE:

1. HEAT TREAT TO SPRING TEMPER.
2. DESIGNED TO CLIP OVER PANELS
FROM .060 [1.52] THRU .070 [1.78] TH'K.
3. * DENOTES $\pm .015$ [$\pm .38$] TOLERANCE

DATE	DESCRIPTION	REV.
10.06.16	CHANGE AS PER ECR 16-061	L
3.24.15	CHANGE AS PER ECN 15-035 (K1) WAS .358 [9.09] ± .015 [±0.38]	K
6.09.09	CHANGE AS PER ECN 09-060	I
12.6.00	CHANGE AS PER ECN 00-119	H

KEYSTONE ELECTRONICS CORP.			
www.keyelco.com • ASTORIA, N.Y. 11105-2017 • Tel (718) 956-8900			
PART NAME		SINGLE 'AAA' 'N' CONTACT	
MATERIAL		.010 [0.25] TH'K ANNEALED SPRING STEEL	
FINISH		DRN BY	DATE
NICKEL PLATE		BOONE	2.1.82
		APP'D	SCALE
		LN	4X
TOLERANCES	INCH [MM]	CODE	DWG NO.
DECIMAL	$\pm .010$ [± 0.25]	C	204
ANGULAR	$\pm 1^\circ$		
UNLESS OTHERWISE SPECIFIED			