

Signal conditioning modules

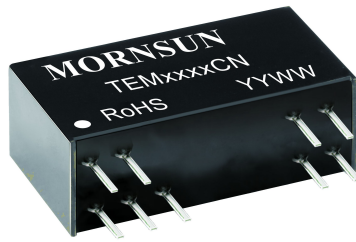

RoHS

PART NUMBER SYSTEM

TEMxxxxCN

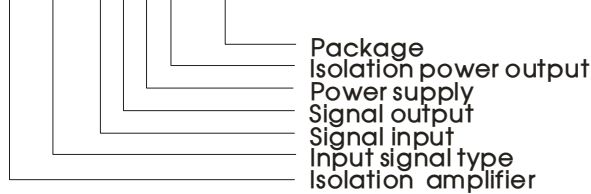

TEMxxxxCN series is analog signal isolation modules with millivolt-class positive/negative voltage signal input and rear-end positive/negative voltage signal output. They are equipped with built-in efficient micro-power source and can supplying power to the internal circuit of the product. The product adopts the electromagnetic isolating technology as a substitute for the traditional linear opto-isolator. In contrast, this type of product has a better performance in temperature drift, linearity, low power consumption and Low ripple. They are two-terminal isolation (input of power supply, signal output and signal output are mutually isolated)

FEATURES

- Two- port isolation (signal input and output are mutually isolated)
- High precision (0.1% F.S.)
- High linearity (0.1% F.S.)
- Isolation voltage (2KVAC/60s)
- Extremely low temperature coefficient (50PPM/°C, within -40 to +85°C)
- Industrial grade (operating temperature range: -40°C to +85°C)
- High reliability (MTBF >500,000 hours)
- Low ripple & noise: ≤35mVp-p(20MHz)
- ESD protection (IEC/EN61000-4-2 Contact ±4KV perf. Criteria B)
- Compact size: DIP Package(26*9.5*12.5mm)
- With load capacity: ≥2KΩ @10V

Selection Guide

Part No.	Power Supply input Typ. (VDC)	Input Signal	Output Signal	Isolation Power Output (VDC)
TEM4540CN	15VDC	±50mV	±10V	None
TEM6540CN	15VDC	±100mV	±10V	None
TEM6640CN	15VDC	±100mV	±5V	None
TEM7650CN	12VDC	±200mV	±5V	None

Note: The isolation power output port can provide a ±5V~±5.5V distribution voltage, load current ≤5mA, if the client need to use, please add the Regulator circuit.

Input Specifications

Item	Operating Conditions		Min.	Typ.	Max.	Unit
Power Input	Input voltage		Typ.-5%	Typ.	Typ.+5%	VDC
	Input power	Signal full load	--	--	1.0	W
	Input protection		Anti-reverse Connection protection			
signal Input	Input signal		See selection guide			
	Input impedance	in case of max. input of voltage signal	10	--	--	MΩ
	Over range		-10	--	+10	V

Output Specifications

Item	Operating Conditions		Min.	Typ.	Max.	Unit
signal Output	Output signal		See selection guide			
	Load capacity	Voltage output	2	--	--	KΩ
	Power supply regulation		-0.05%F.S.	--	+0.05%F.S.	--
	Load regulation		-0.05%F.S.	--	+0.05%F.S.	--
	Ripple & noise	Bandwidth 20MHz	--	--	35	mVp-p

Transmission Specifications

Item	Operating Conditions		Min.	Typ.	Max.	Unit
Zero Offset			-0.1%F.S.	--	+0.1%F.S.	--
Signal Precision			-0.1%F.S.	--	+0.1%F.S.	--

Temperature Coefficient	Operating temperature range of -40 to +85℃	--	--	50	PPM/℃
Bandwidth		2	--	--	KHz
Response Time		--	--	1	ms

General Specifications

Item	Operating Conditions	Min.	Typ.	Max.	Unit
Electric Isolation		Power input and the signal output are on the common ground. Isolated between signal input terminal and signal output terminal.			
Degree of Isolation	testing for 1 minute, leakage current <1mA, humidity <70%	2	--	--	KVAC
Isolation Resistance	500VDC	100	--	--	MΩ
Operating Temperature		-40	--	+85	℃
Transportation and Storage Temperature		-50	--	+105	℃
Casing Temperature Rise	Ta=25℃	--	--	55	℃
Application Environment		The presence of dust, fierce vibration, impulsion and corrosive gas may cause damage to the product			

Physical Specifications

Casing Material	Black flame-retardant and heat-resistant plastic
Package	DIP18
Weight	8g(Typ.)
Cooling Method	Free convection

EMC Specifications

EMS	ESD	IEC/EN61000-4-2	Contact ±4KV	perf. Criteria B
	EFT	IEC/EN61000-4-4	signal input port ±1KV (see Fig. 4 for recommended circuit)	perf. Criteria B
	Surge	IEC/EN61000-4-5	signal input port ±1KV(line-to-ground) (see Fig. 4 for recommended circuit)	perf. Criteria B

Application Precautions

1. Please read the instructions carefully before use; contact our technical directly if you have any problem.
2. Do not use the product in hazardous areas.
3. Use DC power supply for the product and 220V AC power supply is prohibited.
4. Do not dismantle and assemble the product without permission to avoid failure or malfunction of equipment.
5. Unless otherwise specified, parameters in this datasheet were measured under the conditions of Ta=25℃, humidity<75% with power input nominal voltage and rated signal output full load.

After-sales service

1. Ex-factory inspection and quality control have been strictly conducted for the product; if there occurs abnormal operation or possibility of failure of internal module, please contact the local representative or our technical support.
2. The warranty period for the product is 3 years as calculated from the date of delivery. If any quality problem occurs under normal use within the warranty period, the product can be repaired or changed for free.

Applied circuit

Please refer to Isolated Transmitter application notes.

Design Reference

1. Wiring diagram for product application

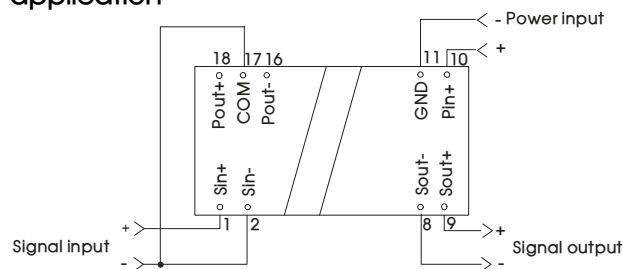

Fig. 1

Note: The other applications required short rest 2 pin and 17 pin besides Figure (b) shows in the typical application circuit three

2. Typical application circuit

Typical application circuit one: Positive and negative power supply current signal detection scheme

The signal conditioning module TEMxxxCN series, in the dual power supply conditions (VCC, VEE), can be used to detect any direction's current values. As shown in the Fig. 1, if the current detection resistor series to the current loop, then the loop current will generate mV level voltage signal in the resistance, the signal conditioning modules, complete signal amplification, and feedback to the back-end instrument.

The resistance values, to be measured current's range, and the signal conditioning modules should be matched, such as: needs to detect the ±5A current, signal conditioning modules select ±100mV model, so the detecting resistors should be 20mΩ, and the resistance value can be realized by controlling the PCB line length.

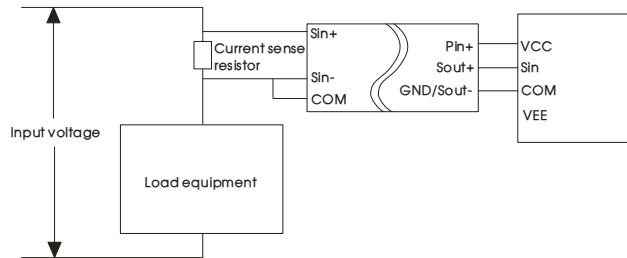

Fig. 2

Typical application circuit two: Single power supply and an absolute value circuit scheme

Based on the application scheme one, if only provide a single power supply VCC for the signal conditioning modules, then, by using the above figure's peripheral circuit, we can calculate the absolute value for the output signal. As shown in the figure, the Sout+ pin is positive voltage signal, the first stage operational amplifier and a diode are not working, second stage operational amplifier is working, the output voltage equal to Sout+ pin's voltage. The Sout+ pin's signal is positive voltage, the first stage operational amplifier will reverse the signal, the second stage operational amplifier output voltage equal to the voltage on the Sout+ pin, but in the opposite direction. Therefore, it realizes the absolute value operation for the Sout+ pin voltage signal.

In the figure, the values of two output resistance should consider the power consumption and their divider for second stage operational amplifier's input impedance, here to recommend 10KΩ.

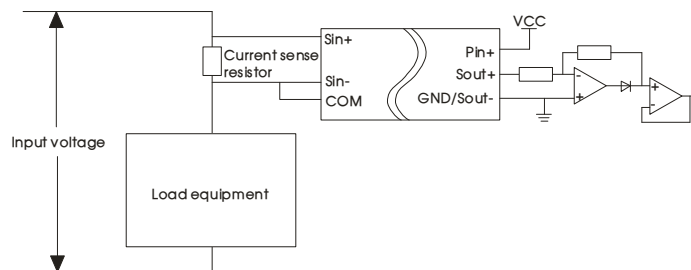

Fig. 3

Typical application circuit three: The detection scheme based on the resistance bridge pressure

As shown in the figure, the pressure strain resistance is connected in a bridge structure, the change in pressure makes the corresponding change of resistance value, and in the bridge circuit, the change of the resistance will cause the voltage change between the Sin+ and Sin- pins. This voltage is typically mV level, but signal conditioning modules can make the signal from mV level amplify to V level, for the back end uses.

$$V_{sin} = V_{ref} \left(\frac{R3}{R3 + R4} - \frac{R2}{R1 + R2} \right)$$

To match it, let R1=R2=R3=R, R3 is the pressure strain resistance, Vsin is the voltage between Sin+ and Sin- pins. The above equation can be simplified to

$$V_{sin} = V_{ref} \left(\frac{R}{R + R3} - \frac{1}{2} \right)$$

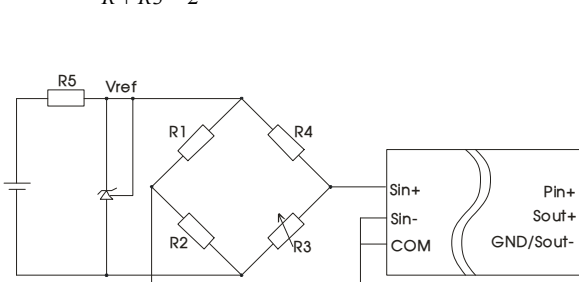

Fig.a

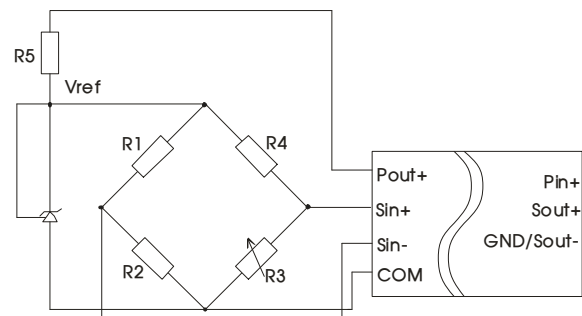

Fig.b

3. Recommended EMC circuit

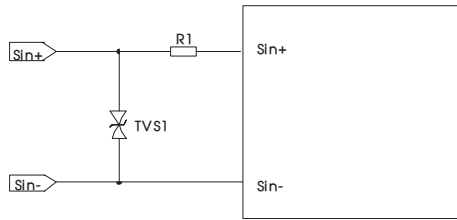
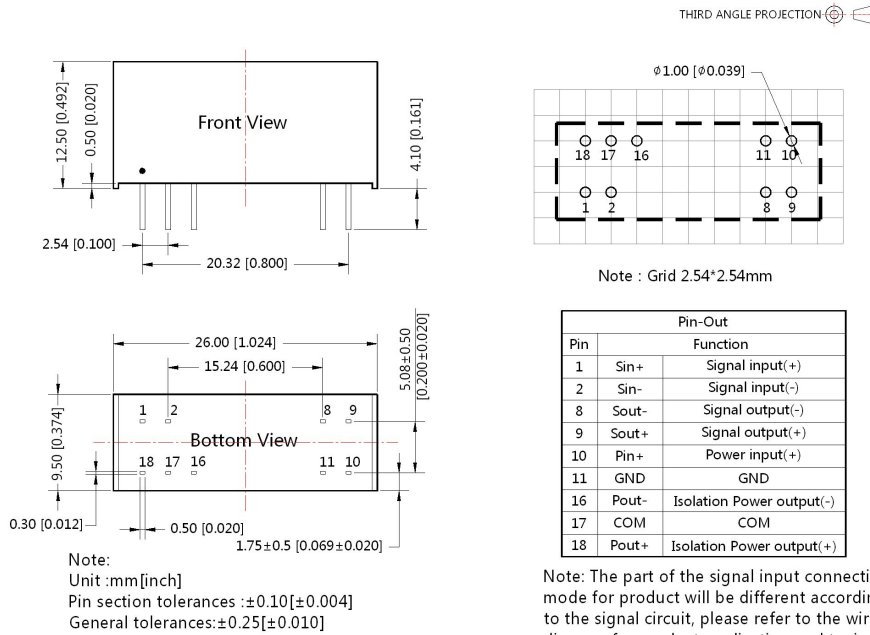

Fig. 4

Components	Recommended parameters
R1	12 Ω /2W
TVS1	SMBJ5CA

4. For more information please find the application notes on www.mornsun-power.com

Dimensions and Recommended Layout



Notes:

1. Packing information please refer to Product Packing Information which can be downloaded from www.mornsun-power.com. Packing bag number: 58240002;
2. All index testing methods in this datasheet are based on our Company's corporate standards;
3. The performance parameters of the product models listed in this manual are as above, but some parameters of non-standard model products may exceed the requirements mentioned above. Please contact our technicians directly for specific information;
4. We can provide product customization service;
5. Specifications are subject to changes without prior notice.

Mornsun Guangzhou Science & Technology Co., Ltd.

Address: No. 5, Kehui St. 1, Kehui Development Center, Science Ave., Guangzhou Science City, Luogang District, Guangzhou, P. R. China
Tel: 86-20-38601850-8801 Fax: 86-20-38601272 E-mail: info@mornsun.cn